

PARTS LIST			
ITEM	QTY	PART NUMBER	DESCRIPTION
1	1		Label,Buderus,Man. Date
2	1		Label,Buderus,Pump Speed
3	1		Tube,Bent,Steel,1" Assembly
4	1		Tube,Tee,Steel,1" Kit
5	1		Base,3" Box,Assembly
6	1		Nipple,Stl,Galv,1"x1-1/2"
7	2	0546827	Vlv,Ball,FBV-3C,1"
8	2	0821727	Union,Dielectric 1",FxF NPT
9	2	81003573	Flange,1",Iron Grundfos
10	1	81004963	Vlv,T&P,3/4,Safety,330M1
11	1	81005062	Pump,GF,UPS15-58FC/LC-9H
12	1	81005064	Box,Buderus,35x20x10
13	2	81005511	Screen,SS,GB142
14	1	81005512	Cplng,Red,1-1/2x3/4,PVC
15	1	81005513	T,Red,3 x 3 x 3/4,PVC
16	1	81005769	Manual,Buderus GB142
17	1	81007900	Manual,Buderus,ServBull
18	1	81007901	Manual,Buderus,A10Adndum
19	1	81009188	Manual,GB142 Service
20	4	81009683	Buderus,Corner,Stiffners

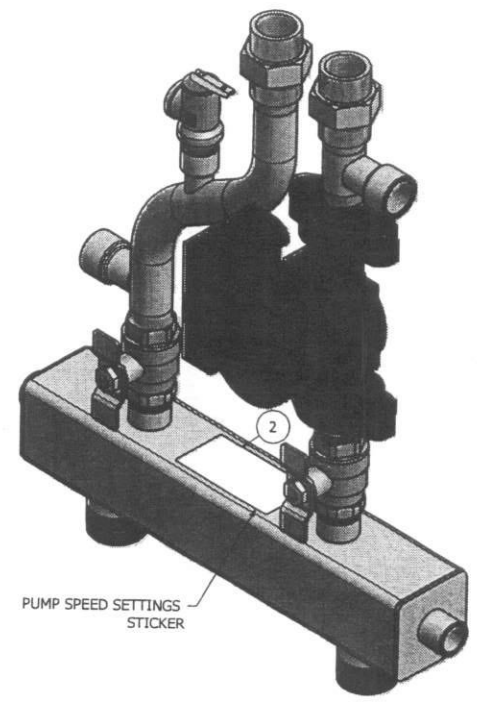
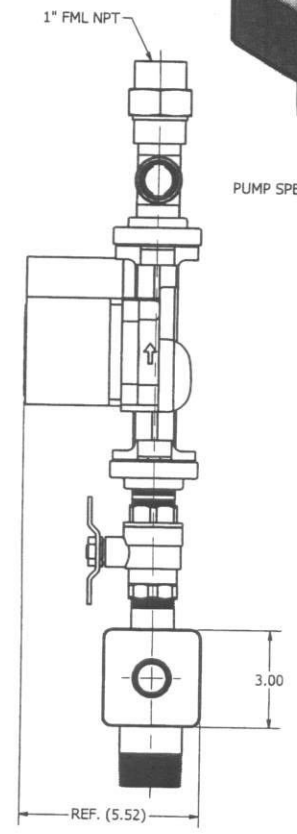
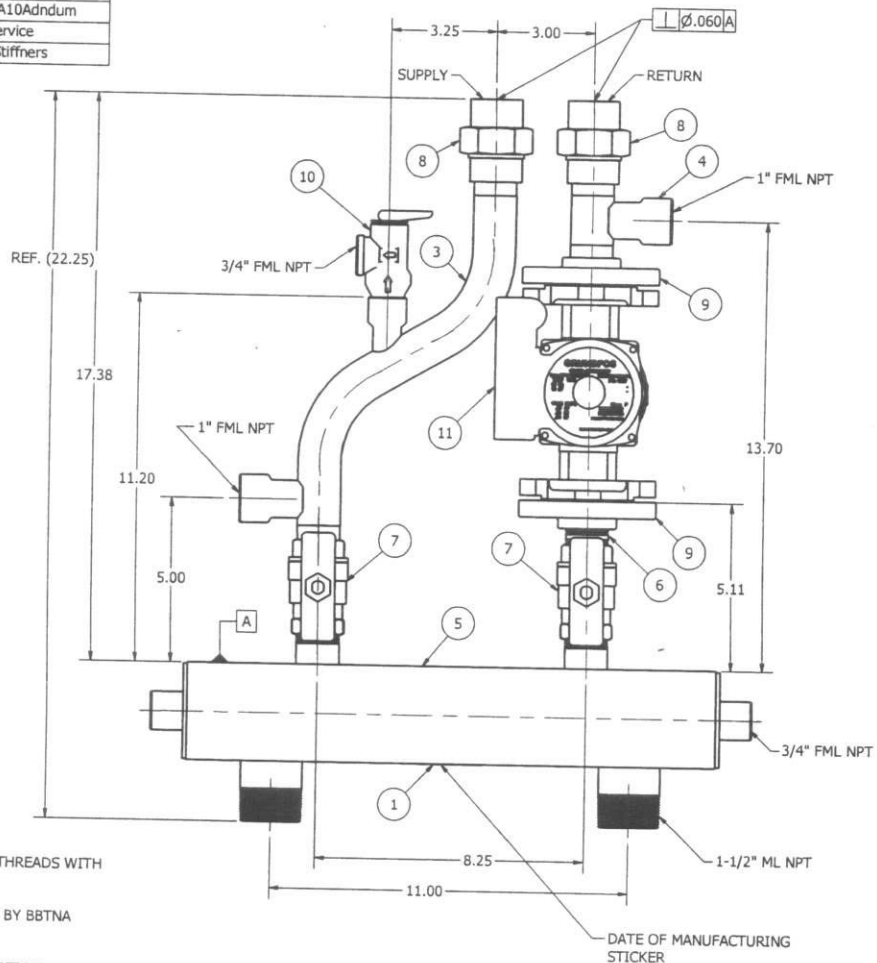
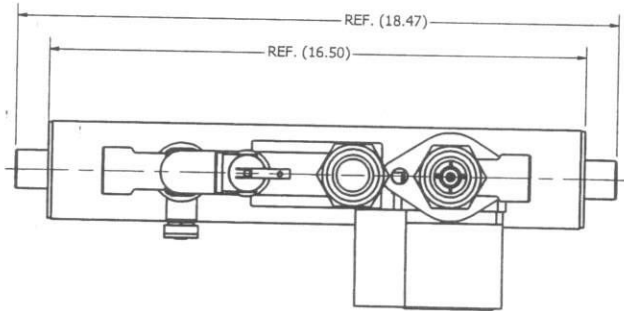

- NOTES:
- CUT PLUGS FROM POWER CORDS ON PUMPS.
 - USE TEFLON PASTE ON CONNECTIONS SEALED BY THREADS WITH LOCTITE 567
 - MODIFICATIONS OR CHANGES MUST BE APPROVED BY BBTNA PRIOR TO IMPLEMENTATION.
 - FILLER METAL ALLOY ER70S-6 WITH 100% PENETRATION.
 - UNIT TO BE TESTED AS A COMPLETE ASSEMBLY. ZERO BUBBLE WATER SUBMERSION 100 PSI AIR.
 - POWDER COAT WITH HENTZEN P90082KPC BLACK POLYESTER.

- REQUESTED NOTES:
- MAX HIEGHT: 22.25"
MAX WIDTH: 18.47"
MAX DEPTH: 5.52"
APPROX. WIEGHT: 36.31lb
 - PUMP SPEC:
GRUNDFOS UPS15-58FC/LC-9H
 - SHIPPING BOX SIZE:
35"x20"x10"

UNLESS OTHERWISE SPECIFIED: DIMENSIONS ARE IN INCHES AND TO THE INTERSECTION OF SURFACE EXTENSION LINES.		FRACTIONAL ± 1/64 DECIMAL .XXX ± 0.10 DECIMAL .XX ± 0.03 ANGULAR ± 1'00"	MATERIAL	STOCK SIZE	SCALE	FINISH
REMOVE ALL BURRS, BREAK SHARP EDGES .005-.015 RADIUS, CORNER FILLETS .005-.020 RADIUS, SURFACE ROUGHNESS 125μ	APPROVED	NAME D GALBRAITH	DATE 3/18/2009	←	PRINTS BEFORE DRAWN DATE ARE VOID	DESCRIPTION Mod,GB142,LLH,3"
WATTS RADIANT, INC. 488 E. Progress Pkwy. Springfield, Illinois 62781	THIS DRAWING DISCLOSES CONFIDENTIAL AND OTHER DATA OF A PROPRIETARY NATURE OWNED BY WATTS WATER TECHNOLOGIES, INC. AND MAY NOT BE USED OR DISCLOSED TO OTHERS WITHOUT THE PRIOR WRITTEN CONSENT OF WATTS WATER TECHNOLOGIES, INC.	EDP NUMBER 0450069	REV. 0			