

Series RFII — 5.6 K-factor “Royal Flush II” Concealed Pendent Sprinklers Quick & Standard Response, Standard Coverage

IMPORTANT

Refer to Technical Data Sheet TFP2300 for warnings pertaining to regulatory and health information.

Always refer to Technical Data Sheet TFP700 for the “INSTALLER WARNING” that provides cautions with respect to handling and installation of sprinkler systems and components. Improper handling and installation can permanently damage a sprinkler system or its components and cause the sprinkler to fail to operate in a fire situation or cause it to operate prematurely.

Scan the QR code or enter the URL in a web browser to access the most up-to-date electronic version of this document. Data rates may apply.



docs.jci.com/tycofire/TFP181

General Description

The TYCO Series RFII 5.6 K-factor, “Royal Flush II” Concealed Pendent Sprinklers Quick Response (3-mm bulb) and Standard Response (5-mm bulb), are decorative sprinklers featuring a flat cover plate designed to conceal the sprinkler. These sprinklers are optimal for architecturally sensitive areas such as hotel lobbies, office buildings, churches, and restaurants.

Each sprinkler includes a cover plate/retainer assembly and a sprinkler/support cup assembly. The separable, two-piece assembly design provides the following benefits:

- Allows installation of the sprinklers and pressure testing of the fire protection system prior to installation of a suspended ceiling or application of the finish coating to a fixed ceiling.
- Permits the removal of suspended ceiling panels for access to building service equipment without having to first shut down the fire protection system and remove sprinklers.
- Provides for 1/2 in. (12,7 mm) of vertical adjustment to allow a measure of flexibility in determining the length of fixed piping to cut for the sprinkler drops.

The Series RFII Sprinklers are shipped with a disposable protective cap. The protective cap is temporarily removed during installation and replaced to help protect the sprinkler during ceiling installation or finish. The tip of the protective cap can be used to mark the center of the ceiling hole into plaster board or ceiling tiles by gently pushing the ceiling product against the protective cap. When ceiling installation is complete, the protective cap is removed and the cover plate/retainer assembly is installed.

As an option, the Series RFII Standard Response (5-mm bulb) “Royal Flush II” Concealed Pendent Sprinklers can be fitted with a silicone air and dust seal as shown in Figure 5. The air and dust-seal is intended for sensitive areas where it is desirable to prevent air and dust from the area above the ceiling to pass through the cover plate.

NOTICE

The Series RFII Concealed Pendent Sprinklers described herein must be installed and maintained in compliance with this document and with the applicable standards of the NATIONAL FIRE PROTECTION ASSOCIATION (NFPA), in addition to the standards of any authorities having jurisdiction. Failure to do so may impair the performance of these devices.

The owner is responsible for maintaining their fire protection system and devices in proper operating condition. The installing contractor or sprinkler manufacturer should be contacted with any questions.



Sprinkler Identification Number (SIN)

TY3531 — 3 mm bulb
TY3551 — 5 mm bulb

Technical Data

Sprinkler Approvals

Approvals apply only to the service conditions indicated in the Design Criteria section.

- TY3531 (3 mm Bulb) is UL Listed, C-UL Listed and NYC Approved (MEA 353-01-E) as Quick Response.
- TY3531 (3 mm Bulb) is EAC Approved and VdS Approved (Certificate No. G4090007).
- TY3531 (3 mm Bulb) is FM and LPCB Approved (Ref. No. 094a/10) as Standard Response.
Note: FM and LPCB do not approve concealed sprinklers for quick response.
- TY3551 (5 mm Bulb) is UL Listed, C-UL Listed, EAC Approved, FM Approved, LPCB Approved (Ref. No. 094a/9), and NYC Approved (MEA 353-01-E) as Standard Response.

Approvals for Air and Dust Seal

UL and C-UL Listed for use with the RFII Standard Response Concealed Sprinkler (TY3551)

Maximum Working Pressure

Maximum 250 psi (17,3 bar) by UL, C-UL, and NYC

Maximum 175 psi (12,1 bar) by FM, VdS, and LPCB

Temperature Rating

155°F (68°C) Sprinkler with 139°F (59°C) Cover Plate

200°F (93°C) Sprinkler with 165°F (74°C) Cover Plate

Discharge Coefficient

K= 5.6 GPM/psi^{1/2} (80,6 LPM/bar^{1/2})

Adjustment

1/2 in. (12,7 mm)

Finishes

See the Ordering Procedure section.

Physical Characteristics

Frame	Bronze
Support Cup	Plated Steel
Guide Pins	Stainless Steel
Deflector	Bronze
Compression Screw	Brass
Bulb	Glass
Cap	Bronze or Copper
Sealing Assembly	Beryllium Nickel w/TEFLON
Cover Plate	Brass
Retainer	Brass
Ejection Spring	Stainless Steel

Design Criteria

The TYCO Series RFII 5.6 K-factor, "Royal Flush II" Concealed Pendent Sprinklers are intended for fire protection systems designed in accordance with the standard installation rules recognized by the applicable Listing or Approval agency; for example, UL Listing is based on NFPA 13 and VdS Approval is based on the CEA 4001.

For more information on LPCB and VdS Approvals, contact Johnson Controls at the following office:

Enschede, Netherlands
 Telephone: 31-53-428-4444
 Fax: 31-53-428-3377

The Series RFII Concealed Pendent Sprinklers are only listed and approved with the Series RFII Concealed Cover Plates having a factory applied finish.

NOTICE

Do not use the Series RFII in applications where the air pressure above the ceiling is greater than that below. Down drafts through the sprinkler/support cup assembly can delay sprinkler operation in a fire situation.

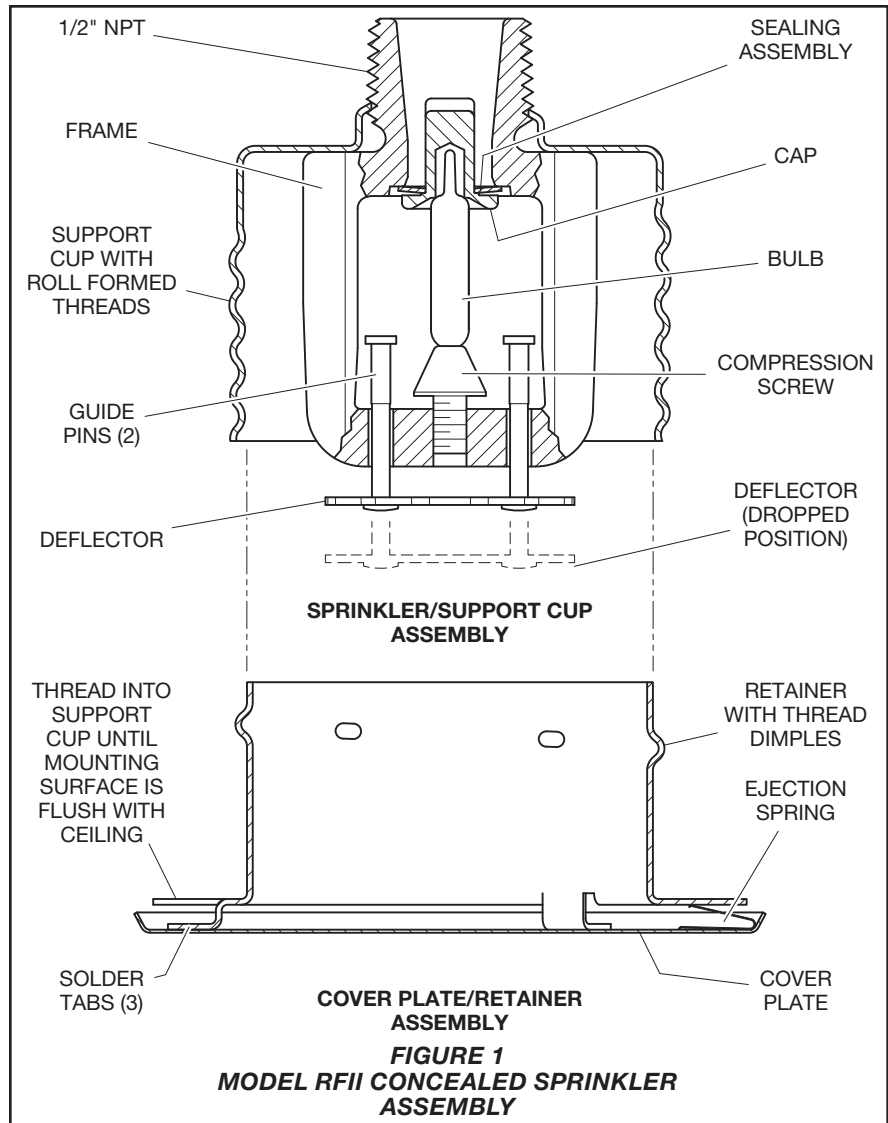

Operation

When exposed to heat from a fire, the cover plate, normally soldered to the retainer at three points, falls away to expose the sprinkler/support cup assembly.

The deflector — supported by the guide pins — then drops down to its operational position.

The glass bulb contains a fluid that expands when exposed to heat. When the rated temperature is reached, the fluid expands sufficiently to shatter the glass bulb, activating the sprinkler and allowing water to flow.

Installation

The TYCO Series RFII 5.6 K-factor, "Royal Flush II" Concealed Pendent Sprinklers must be installed in accordance with this section.

General Instructions

Do not install any bulb-type sprinkler if the bulb is cracked or there is a loss of liquid from the bulb. With the sprinkler held horizontally, a small air bubble should be present. The diameter of the air bubble is approximately 1/16 in. (1,6 mm) for the 155°F (68°C) and 3/32 in. (2,4 mm) for the 200°F (93°C) temperature ratings.

A leak-tight 1/2 in. NPT sprinkler joint should be obtained by applying a minimum to maximum torque of 7 ft-lb to 14 ft-lb (9,5 N-m to 19,0 N-m). Higher levels of torque can distort the sprinkler Inlet with consequent leakage or impairment of the sprinkler.

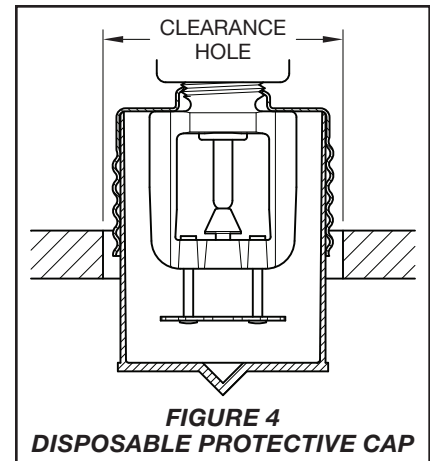
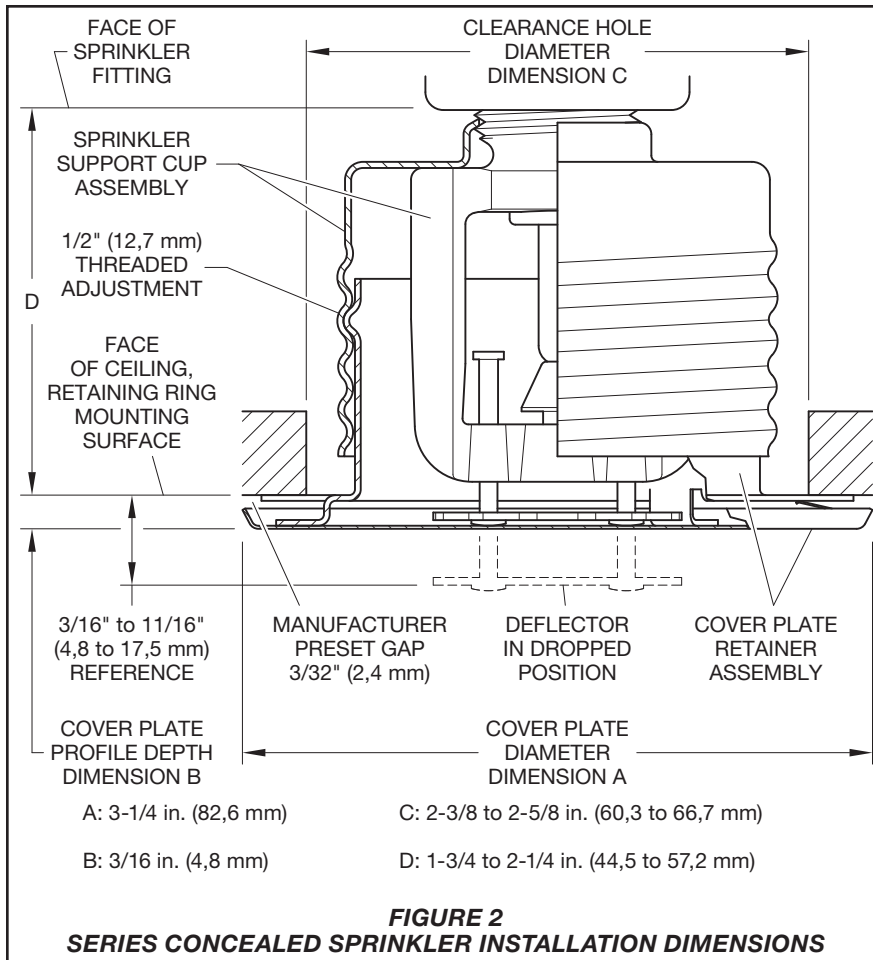

Do not attempt to compensate for insufficient adjustment in the sprinkler by under- or over-tightening the sprinkler/support cup assembly. Re-adjust the position of the sprinkler fitting to suit.

Step 1. Install the sprinkler only in the pendent position with the center-line of the sprinkler perpendicular to the mounting surface.

Step 2. Remove the protective cap.

Step 3. With pipe thread sealant applied to the pipe threads, hand-tighten the sprinkler into the sprinkler fitting.

Step 4. Wrench-tighten the sprinkler using only the RFII Sprinkler Wrench, as shown in Figure 3. Apply the wrench to the sprinkler as shown in Figure 3.

Step 5. Replace the protective cap by pushing it upwards until it bottoms out against the support cup as shown in Figure 4. The protective cap helps prevent damage to the deflector and arms during ceiling installation and/or finish. You can also use the protective cap to locate the center of the clearance hole by gently pushing the ceiling material up against the center point of the protective cap.

NOTICE

As long as the protective cap remains in place, the system is considered "Out of Service".

Step 6. After the ceiling has been completed with the 2-1/2 in. (63,5 mm) diameter clearance hole and in preparation for installing the cover plate/retainer assembly, remove and discard the protective cap. Verify that the deflector moves up and down freely.

If the sprinkler is damaged and the deflector does not move up and down freely, replace the entire sprinkler. Do not attempt to modify or repair a damaged sprinkler.

Step 7. When installing an air and dust Seal, see Figure 5 for reference and

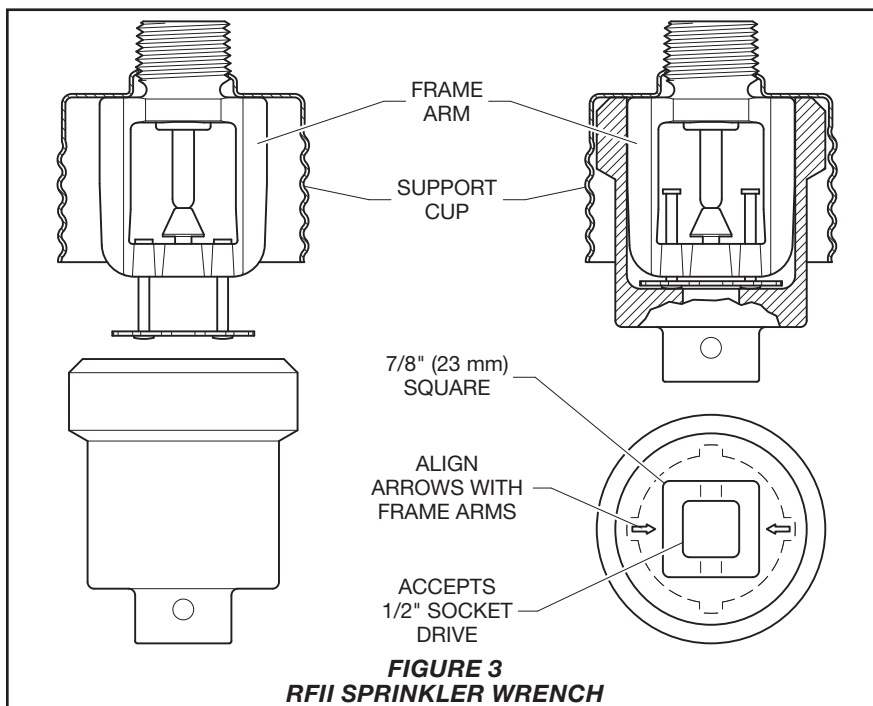

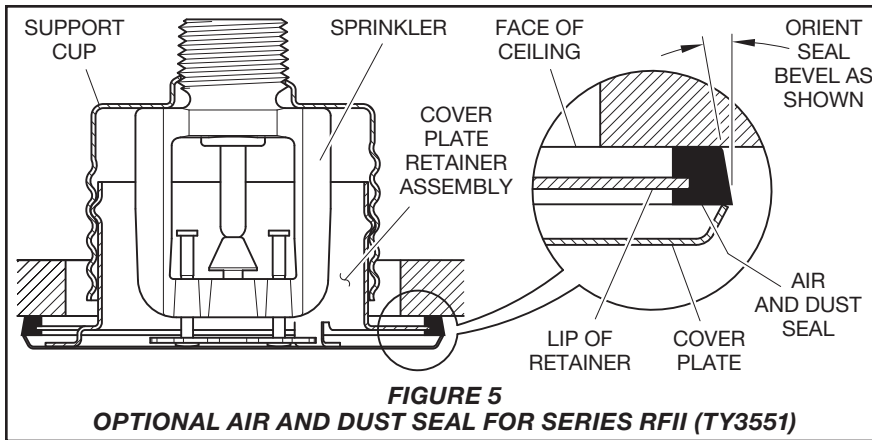

follow this step; otherwise, proceed to Step 8. To attach the air and dust seal, verify the angle of the outside edge of the seal is oriented according to Figure 5. Start the edge of the retainer in the grooved slot of the air and dust seal and continue around the retainer until the entire air and dust seal is engaged.

Step 8. Screw on the cover plate/retainer assembly until the retainer, shown in Figure 2, or the air and dust seal, shown in Figure 5, contacts the ceiling. Do not continue to screw on the cover plate/retainer assembly so that it lifts a ceiling panel out of its normal position. If you cannot engage the cover plate/retainer assembly with the support cup or you cannot engage the cover plate/retainer assembly sufficiently to contact the ceiling, you must reposition the sprinkler fitting.

Care and Maintenance

The TYCO Series RFI 5.6 K-factor, “Royal Flush II” Concealed Pendent Sprinklers must be maintained and serviced in accordance with this section.

Before closing a fire protection system main control valve for maintenance work on the fire protection system that it controls, obtain permission to shut down the affected fire protection system from the proper authorities and notify all personnel who may be affected by this action.

Absence of the cover plate/retainer assembly can delay sprinkler operation in a fire situation.

When properly installed, there is a nominal 3/32 in. (2.4 mm) air gap between the lip of the cover plate and the ceiling, as shown in Figure 2.

This air gap is necessary for proper operation of the sprinkler. If the ceiling requires repainting after sprinkler

installation, ensure that the new paint does not seal off any of the air gap.

Do not pull the cover plate relative to the enclosure. Separation may result.

Sprinklers which are found to be leaking or exhibiting visible signs of corrosion must be replaced.

Automatic sprinklers must never be painted, plated, coated, or otherwise altered after leaving the factory. Modified sprinklers must be replaced. Sprinklers that have been exposed to corrosive products of combustion, but have not operated, should be replaced if they cannot be completely cleaned by wiping the sprinkler with a cloth or by brushing it with a soft bristle brush.

Care must be exercised to avoid damage to the sprinklers - before, during, and after installation. Sprinklers damaged by dropping, striking, wrench twist/slippage, or the like, must be replaced. Also, replace any sprinkler that has a cracked bulb or that has lost liquid from its bulb. For information about replacing a sprinkler, see the Installation Section.

Exercise care to avoid damage to sprinklers before, during, and after installation. Replace sprinklers damaged by dropping, striking, wrench twisting, wrench slipping, or the like. Also, replace any sprinkler that has a cracked bulb or that has lost liquid from its bulb. For information about replacing a sprinkler, see the Installation section.

If you must remove a sprinkler, do not reinstall it or a replacement without reinstalling the cover plate/retainer assembly. If a cover plate/retainer assembly becomes dislodged during service, replace it immediately.

The owner is responsible for the inspection, testing, and maintenance of their fire protection system and devices in compliance with this document, as well as with the applicable standards of the NATIONAL FIRE PROTECTION

ASSOCIATION such as NFPA 25, in addition to the standards of any other authorities having jurisdiction. Contact the installing contractor or sprinkler manufacturer regarding any questions.

Automatic sprinkler systems should be inspected, tested, and maintained by a qualified inspection service in accordance with local requirements and/or national code.

Limited Warranty

For warranty terms and conditions, visit www.tyco-fire.com.

Ordering Procedure

Contact your local distributor for availability. When placing an order, indicate the full product name.

Sprinkler/Support Cup Assembly
 Specify: Series RFI (specify SIN), K=5.6, “Royal Flush II” Pendent Sprinklers (specify) temperature rating, P/N* (specify):

	155°F (68°C)	200°F (93°C)
TY3531	51-792-1-155	51-792-1-200
TY3551	51-790-1-155	51-790-1-200

* Use Suffix “I” for ISO 7-1 connection; for example, 51-792-1-155-I

Separately Ordered Cover Plate/Retainer Assembly:

Specify: (temperature rating from below) Series RFI Concealed Cover Plate with (finish), P/N (specify).

	139°F (59°C)(a)	165°F (74°C)(b)
Grey White (RAL9002)	56-792-0-135	56-792-0-165
Brushed Brass	56-792-1-135	56-792-1-165
Brass	56-792-2-135	56-792-2-165
Pure White (c) (RAL9010)	56-792-3-135	56-792-3-165
Signal White (RAL9003)	56-792-4-135	56-792-4-165
Jet Black (RAL9005)	56-792-6-135	56-792-6-165
Terra Brown (RAL8028)	56-792-7-135	56-792-7-165
Brushed	56-792-8-135	56-792-8-165
Chrome	56-792-9-135	56-792-9-165
Custom	56-792-X-135	56-792-X-165

NOTES

- a. For use with 155°F (68°C) sprinklers.
- b. For use with 200°F (93°C) sprinklers.
- c. Eastern Hemisphere sales only.

Sprinkler Wrench

Specify: RFI Sprinkler Wrench, P/N 56-000-1-075

Air and Dust Seal

Specify: Air and Dust Seal, P/N 56-908-1-001



TFP181 Change History Appendix

ISSUE DATE	NOTES
08-22	Page 1, updated QR code and URL; Page 4, changed corporate address and telephone number to 1467 Elmwood Avenue, Cranston, RI 02910 Telephone +1-401-781-8220, formerly 1400 Pennbrook Parkway, Lansdale, PA 19446 Telephone +1-215-362-0700.
04-22	Page 1, added QR code and URL to allow convenient access to electronic version from printed document; Page 1, Sprinkler Approvals sub-section, added EAC Approved; Page 4, Ordering Procedure, added Terra Brown (RAL8028) cover plate options, 135°F P/N 56-792-7-135 and 165°F P/N 56-792-7-165.
08-20	Ordering Procedure: Changed Jet Black finish 165°F (74°C) cover plate assembly from part number to 56-792-6-165, formerly 59-792-6-165.
02-20	Ordering Procedure: Changed Brass finish to Brushed Brass, part numbers unchanged; Added new Brass finish with new, unique part numbers.
03-19	Clarified Johnson Controls corporate name in Design Criteria section when seeking more information on LPCB and VdS Approvals.
09-18	Removed Chrome from description of Support Cup; Removed finish option from Ordering Procedure for Sprinkler/Support Cup Assembly.
08-18	Updated Tyco® branding and document format; Added Johnson Controls copyright; Added disclaimer stating specifications and information subject to change without notice; Added reference to Regulatory and Health Warning Technical Data Sheet TFP2300.
04-16	Clarified VdS Approval for TY3531 3 mm bulb sprinkler; Added note to Ordering Procedure Sprinkler sub-section for ordering sprinkler with ISO 7-1 pipe threads, indicated by adding 'I' suffix to part number.
03-13	Updated and standardized RAL color finishes.
09-11	Clarified approval information; Added part number for Brushed Chrome finish cover plate.
10-09	Clarified VdS Approval information.
07-09	Added VdS Approval information.
05-08	Changed Temperature Rating of Cover Plate to 139°F (59°C), formerly 135°F (57°C); Updated standard order cover plate finishes.
01-08	Removed TY3504 and TY3505; Changed UL and C-UL Listed and NYC Approved Maximum Working Pressure to 250 psi (12,1 bar).
07-04	Added reference to Installer Warning data sheet TFP700; Added LPCB Approval; Added option for White RAL9010 for Eastern Hemisphere sales.
01-03	Added new Tyco Fire & Building Products masthead.
02-02	Release of New Technical Data Sheet TFP181 describing Series RFI Concealed Sprinkler