

Installation Manual

Revolving Shoe-Storage System





Model No. DVXZXJ0800C-E

To Installer : Make sure to pass this integrated Precautions for Use to the customer after installation.

- To ensure correct installation, be sure to read these instructions carefully before you install the Product.
- Please properly dispose of the packing materials and residual materials in accordance with legal provisions.









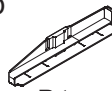
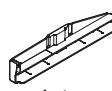
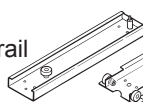

Safety Precautions

Be sure to observe the following precautions.

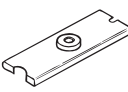
 CAUTION			
 Prohibited	<ul style="list-style-type: none"> ● During construction, do not modify the product to change the product specifications. If the product is so modified that the product specification is changed, we may not be responsible for the product quality assurance. 	 Be sure to observe.	<ul style="list-style-type: none"> ● Check that the cabinet to be installed is securely fixed to the wall or equivalent. If not the product may tip over when being rotated, and may cause personal injury and damage.
 Be sure to observe.	<ul style="list-style-type: none"> ● Use the designated screws. If not, the product may turn over, and accordingly injure you. 		<ul style="list-style-type: none"> ● For proper cabinet installation the wall or equivalent must be a thickness of 15 mm or more for sufficient strength. If you use materials with less strength, such as those of flush structure (hollow structure) or MDF materials, the product may turn over, and cause damage and personal injury.
	<ul style="list-style-type: none"> ● Tighten the parts securely. If not, the product may turn over, and accordingly injure you. 		

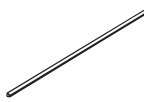
Parts List

The Product components and parts are packaged as shown below. Check the contents.

Part	Quantity	Part	Quantity
Main frame (Top slide rail with upper and lower arms) 	1	Shelf board side cap  R type (right)  L type (left)	6 each
Top/bottom fixed rails Top fixed rail  Bottom fixed rail 	1 each	Shelf bracket (for askew mounting)  L type (left)  R type (right)	5 each
Bottom slide rail 	1	Shelf bracket (for horizontal mounting)  H type (horizontal)	2
Fall prevention bar 	6	Top/bottom fixed rail mounting screw 	12
Handle 	1	Arm screw (with spring washer, washer, and bush) Pan head M5 x 10 	2 each
Shelf 	6		

Installation Procedures

[Dimensional unit: mm]

Configuration

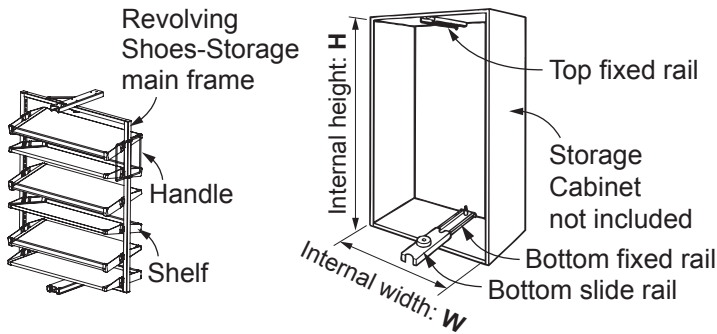

1 Installing top fixed rail

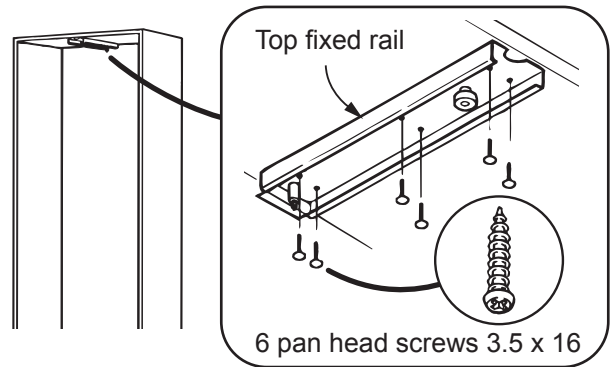

2 Installing bottom fixed rail and bottom slide rail

1. Installing bottom fixed rail

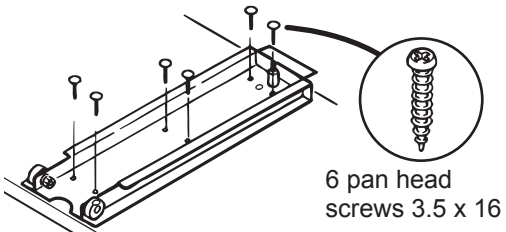

CAUTION Tighten the rail securely with screws.

2. Installing bottom slide rail

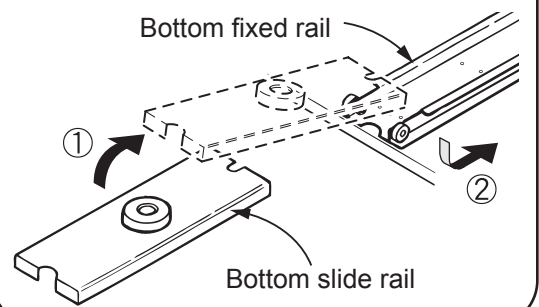

Top/bottom fixed rail component mounting position

CAUTION

For both top and bottom fixed rails, no notable positional displacement is allowed in the horizontal or vertical direction. A large positional displacement between the top and bottom rails, if any, may cause noise or failure of the unit when rotating it.

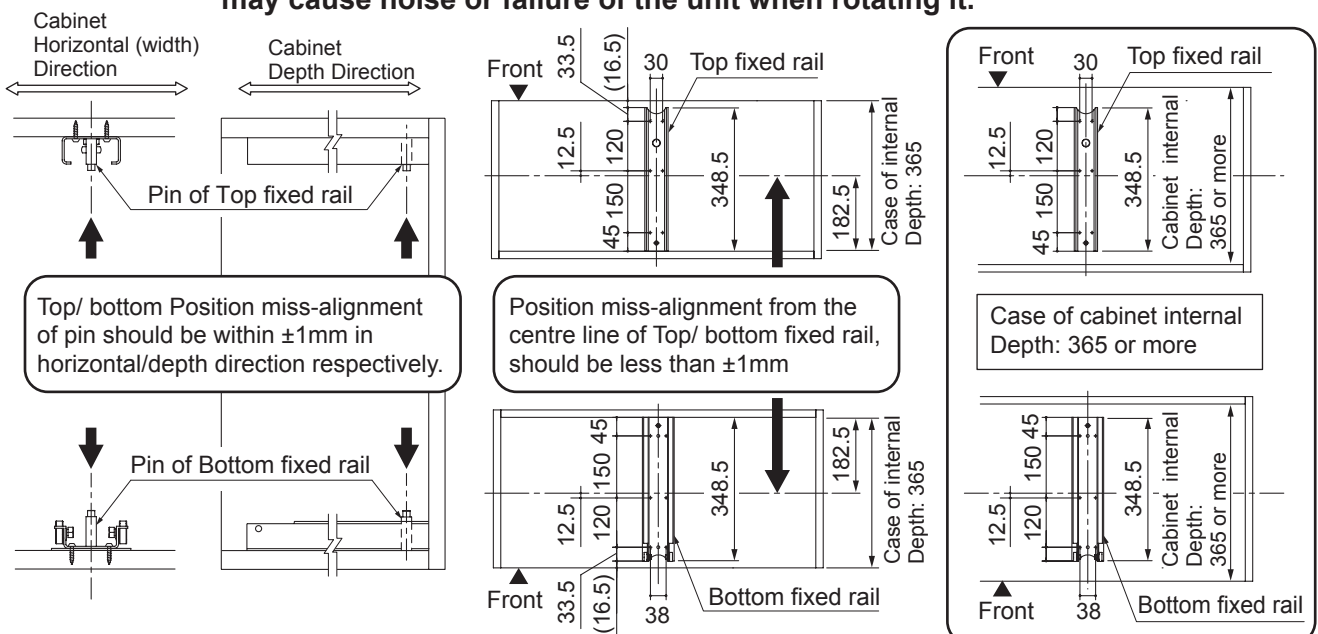

*Make the cabinet inclination in horizontal or vertical direction less than 1mm.

*If the dimension of the internal cabinet depth is greater than 365mm, be sure to install main frame to fit the center position of cabinet.

3 Installing main frame

Mount the upper and lower arm on the top and bottom fixed rails.

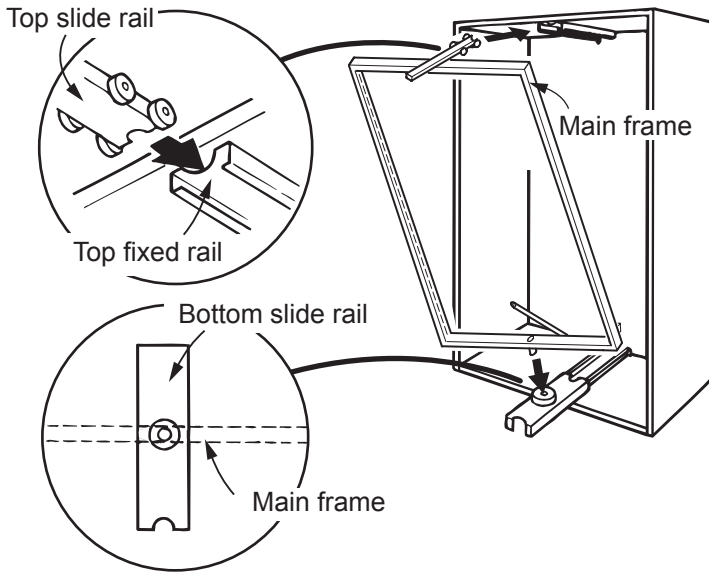

Align the main frame to the bottom slide rail groove in the right direction.

CAUTION



Be sure to observe.

Fix the mounting screws firmly.
(Tightening torque: 15 to 20 kgf·cm)

If not, the main frame may fall, and injure you.

Fixing the upper arm

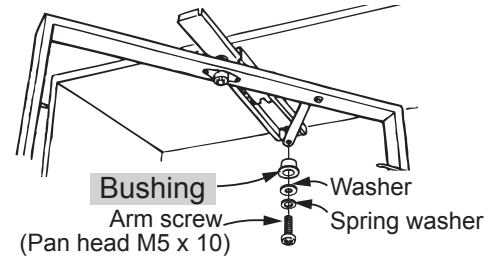

CAUTION Do not mount the bush in the wrong direction.

Fixing the lower arm

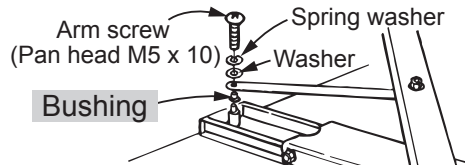

4 Installing Shelves and Fall Prevention Bars

① Shelf side cap

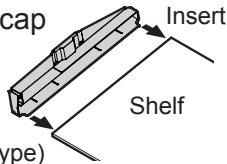

(L type and R type)

② Fall prevention bar

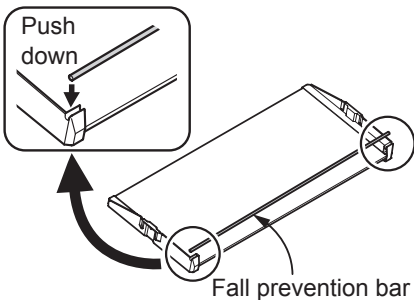

■ Assembling Shelves

- ① Insert both shelf board side caps (L type and R type) into each shelf.
- ② Insert the fall prevention bar into the groove at the front of each shelf side cap, and click into place.

■ Installing Shelves onto Main Frame

- ③ Insert the shelf bracket (L type and R type) into both left and right holes of the main frame.
- ④ Slide the shelf down and engage the shelf brackets with the grooves at both ends of the shelf.

To remove the shelf, do the above operation in the reverse order.

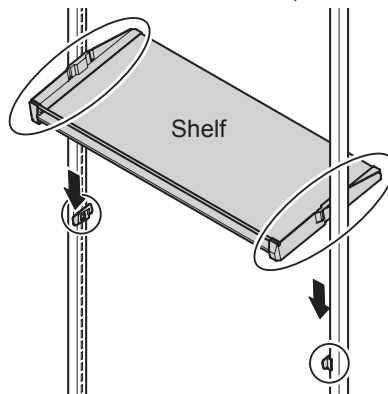

CAUTION

● When installing the shelves, alternate the position of the Fall Prevention Bar (back to front) for each consecutive lower shelf.

● The very bottom shelf is mounted in a fixed horizontal position. Mount this bottom shelf using the H type shelf bracket.

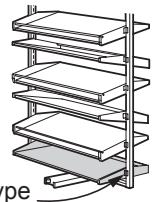

③ Shelf bracket

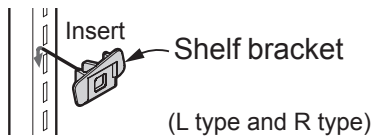

(L type and R type)

④ Installing shelf onto main frame

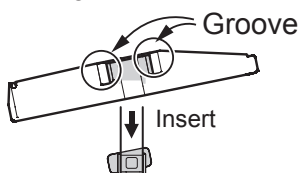

5 Installing the handle

- Handle mounting screws are pre-mounted on the main frame.
- Remove the screws and position the handle as shown. Reinsert the pre-installed screws.

Handle mounting screw

(Pan head tapping screw type III: nominal size 4 x 16)

